

HSF

NOTES:
 Current Rating: 3.2AMP Per Pin(2 Pins Powered)
 Voltage Rating: 250VAC
 Contact Resistance: 30mΩ Max
 Withstand Voltage: 750V AC
 Insulation Resistance: 1000MΩ Min
 Operation Temperature: -55℃ to +125℃
 Contact Material: Copper Alloy
 Contact plating:
 xxu" Gold On Contact Area, (See Ordering Information)
 100u" Matte Tin On Solder Area
 50u" Nickel Underplating Overall
 Insulator And Cap Material: LCP,G.F,UL94V-0,Black

Recommended Process:
 Wave Soldering, Peak Temperature: 260±5℃
 For 10+/-1s

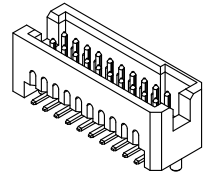

3D VIEW

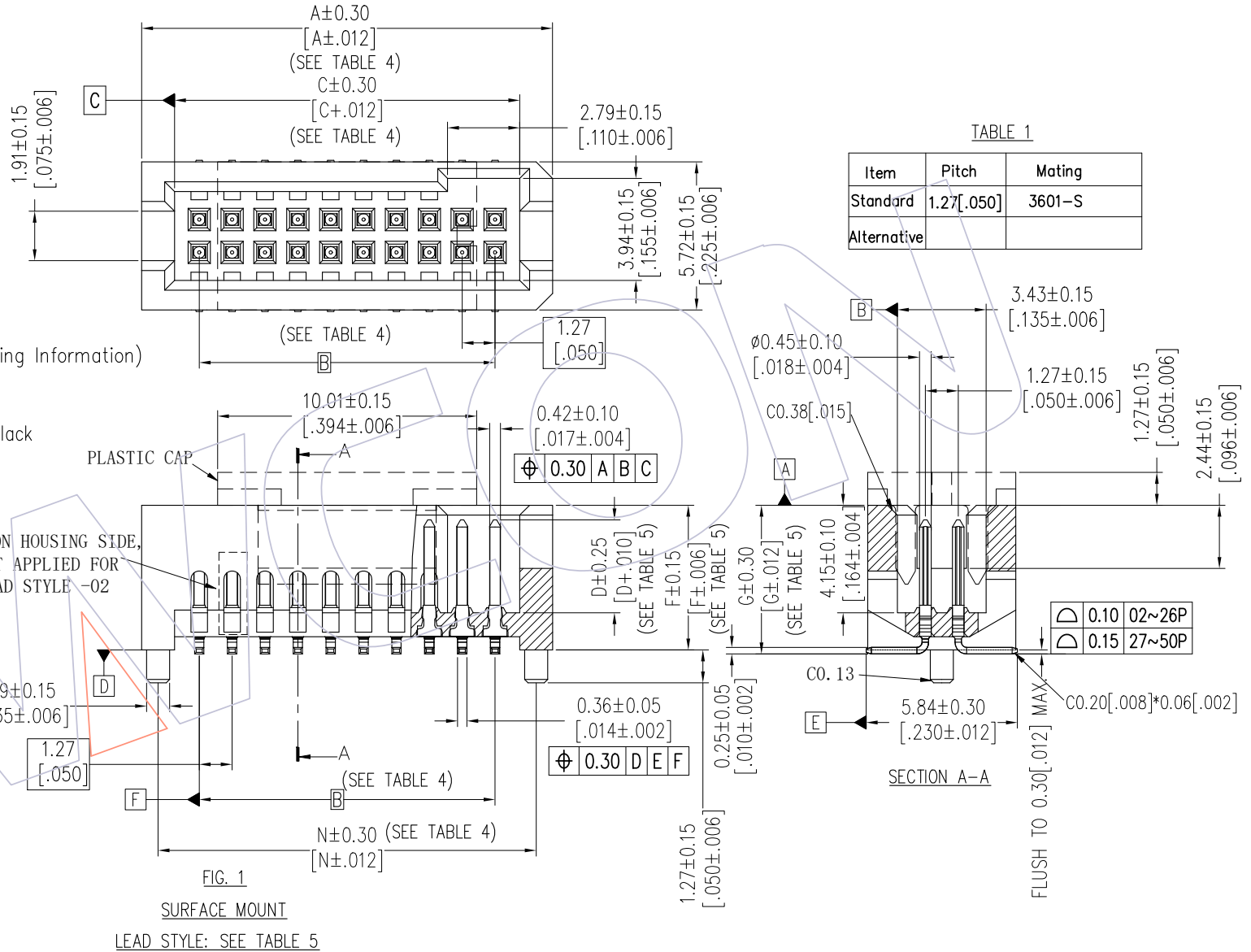

TABLE 1

Item	Pitch	Mating
Standard	1.27 [.050]	3601-S
Alternative		

△ 0.10	02~26P
△ 0.15	27~50P

REV	DATE	MODIFICATION DESCRIPTION	CHANGE	OPERATION	DRAW	DATE	SCALE	FIT	PART NO.
A1	2021/07/22	ADD THE PIN NUMBLE DESCRIPTION IN TABLE 3	YE XIAOBING	x.x ±0.40	YE XIAOBING	2021/07/22	UNIT	mm	3601-PXXX-CXXMXXX01
AO	2020/12/05	NEW	Orwell	x.xx ±0.25	CHECK	DATE	SIZE	A4	TITLE: 1.27mm BTB Male Header W=5.72, -SA STYLE, SMT
				x.xxx ±0.15			SHEET	1/7	Customer NO.
				Angle ± 3°	APPROVE	DATE	PROJ.		
				DIM TOL					

WCON
 Http: www.wcon.com

WCON-Dongguan
 Tel: +86 769 85358920
 Fax: +86 769 85358915
 E-mail: sales@wcon.com

WCON-Kunshan
 Tel: +86 512 57468408
 Fax: +86 512 57468468
 E-mail: salesks@wcon.com

HSF

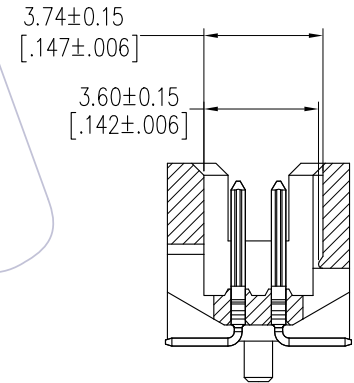
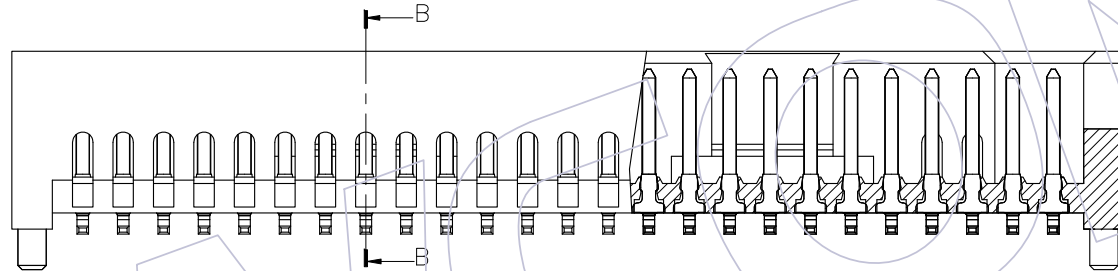
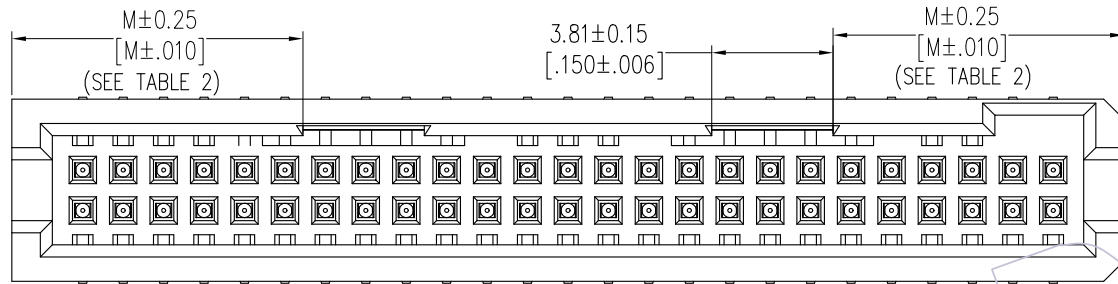

SECTION B-B

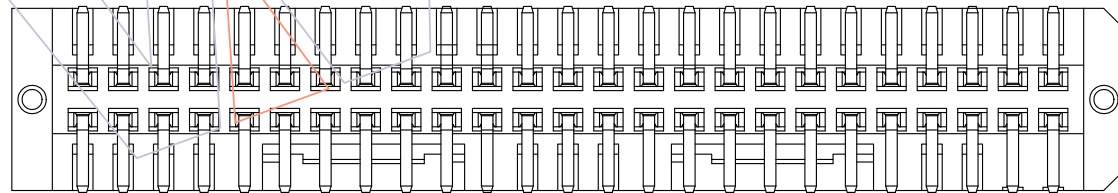

FIG. 2
HOUSING WITH LOCKING
POSITION 25 PER ROW
(SAME AS FIG.1, DIFFERENT AS SHOWN)

TABLE 2

NO. OF POS.	Dim.M
EVEN(EXCEPT 08)	7.87[.310]
ODD(EXCEPT 05, 07)	9.14[.360]
05, 07, 08	2.87[.113]

REV	DATE	MODIFICATION DESCRIPTION	CHANGE	OPERATION	DRAW	DATE	SCALE	FIT	PART NO.
A1	2021/07/22	ADD THE PIN NUMBLE DESCRIPTION IN TABLE 3	YE XIAOBING	x.x ±0.40	YE XIAOBING	2021/07/22	UNIT	mm	3601-PXXX-CXXMXXX01
AO	2020/12/05	NEW	Orwell	x.xx ±0.25	CHECK	DATE	SIZE	A4	TITLE:
				x.xxx ±0.15			SHEET	2/7	1.27mm BTB Male Header
				Angle ± 3°	APPROVE	DATE	PROJ.	Customer NO.	W=5.72, -SA STYLE, SMT
				DIM TOL					

WCON

Http: www.wcon.com

WCON-Dongguan
Tel: +86 769 85358920
Fax: +86 769 85358915
E-mail: sales@wcon.com

WCON-Kunshan
Tel: +86 512 57468408
Fax: +86 512 57468468
E-mail: salesks@wcon.com

HSF

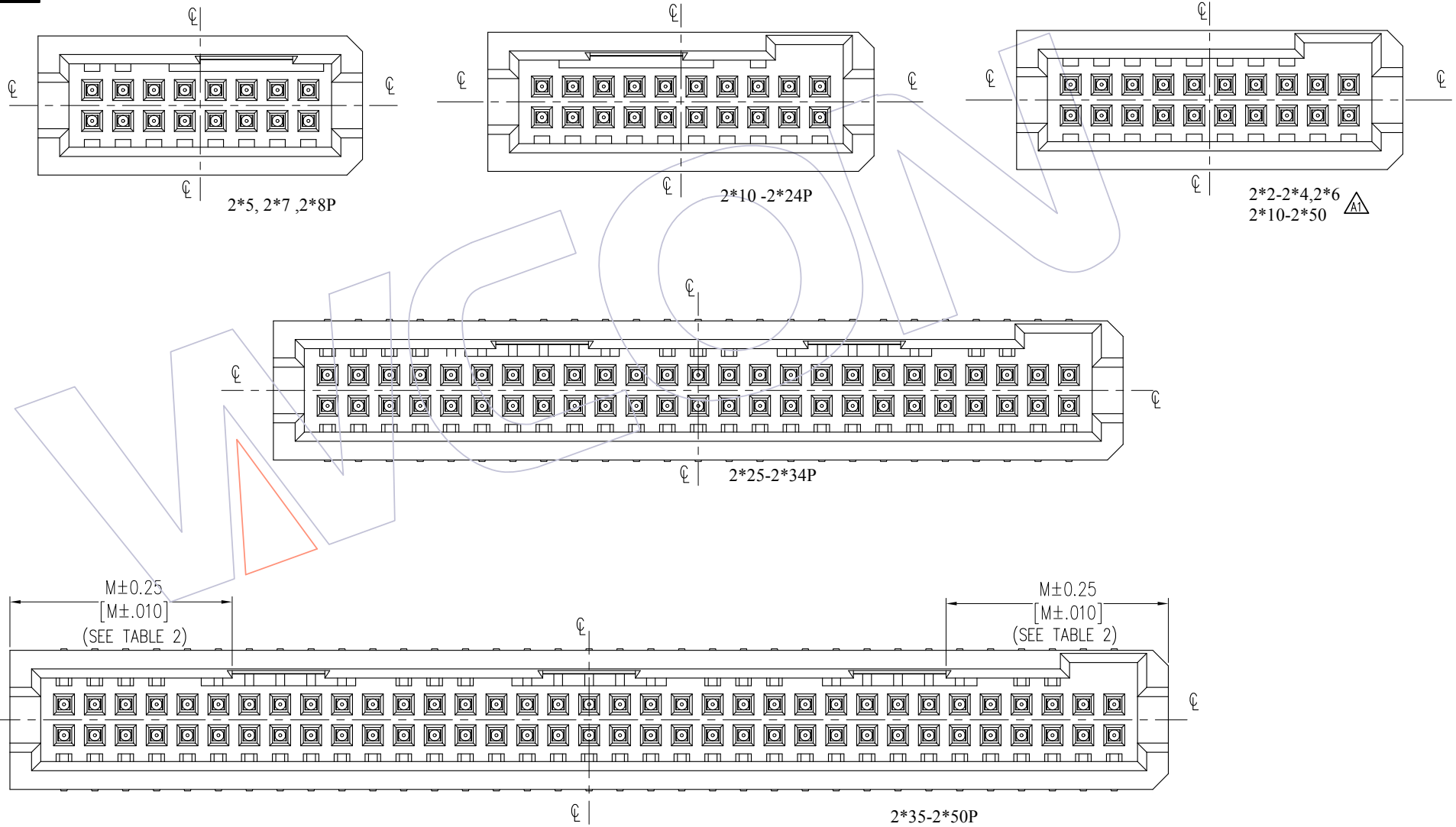

REV	DATE	MODIFICATION DESCRIPTION	CHANGE	OPERATION	DRAW	DATE	SCALE	FIT	PART NO.
A1	2021/07/22	ADD THE PIN NUMBLE DESCRIPTION IN TABLE 3	YE XIAOBING	x.x ±0.40	YE XIAOBING	2021/07/22	UNIT	mm	3601-PXXX-CXXMXXX01
AO	2020/12/05	NEW	Orwell	x.xx ±0.25	CHECK	DATE	SIZE	A4	TITLE: 1.27mm BTB Male Header W=5.72, -SA STYLE, SMT
				x.xxx ±0.15			SHEET	3/7	Customer NO.
				Angle ± 3°	APPROVE	DATE	PROJ.	ϕ	
				DIM TOL					

WCON
Http: www.wcon.com

WCON-Dongguan
Tel: +86 769 85358920
Fax: +86 769 85358915
E-mail: sales@wcon.com

WCON-Kunshan
Tel: +86 512 57468408
Fax: +86 512 57468468
E-mail: salesks@wcon.com

HSF

TABLE 3

No.	Pin Number (Per Row)	POLARIZATION	BUMP LOCKING A	BUMP LOCKING B	BUMP LOCKING C
3	2*5,2*7,2*8	NO	YES	NO	NO
2	2*10-2*24	YES	YES	NO	NO
2	2*25-2*34	YES	YES	YES	NO
2	2*35-2*50	YES	YES	YES	YES
1	2*10-2*50	YES	NO	NO	NO
1	2*2-2*4,2*6	YES	NO	NO	NO



Recommended P.C.B Layout(Top Side)
(PCB BOARD TOLERANCE±0.05)

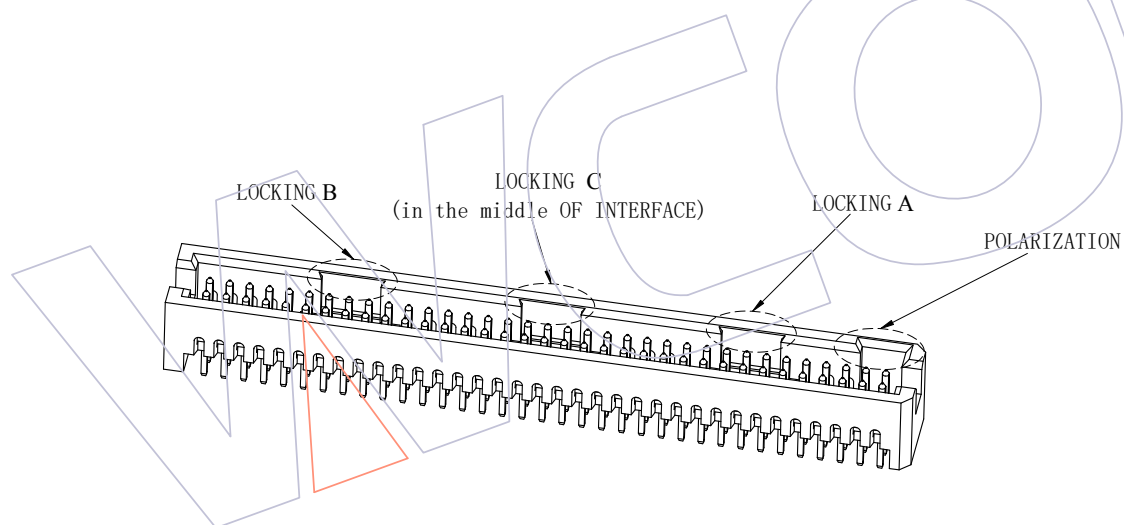
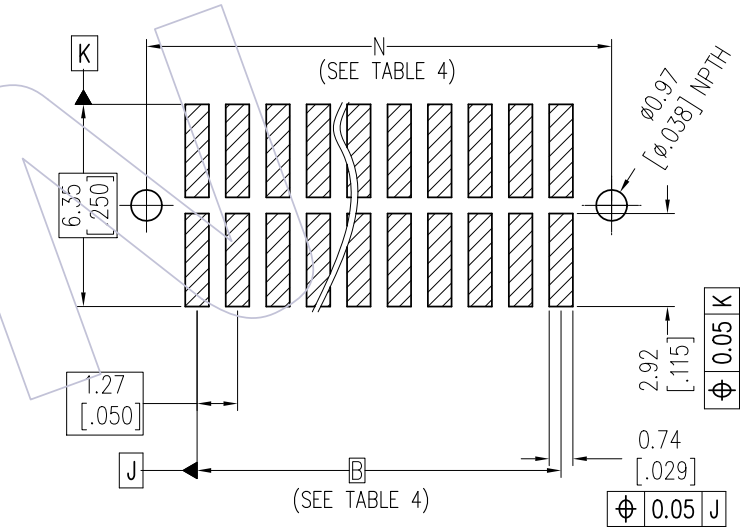

REV	DATE	MODIFICATION DESCRIPTION	CHANGE	OPERATION	DRAW	DATE	SCALE	FIT	PART NO.
A1	2021/07/22	ADD THE PIN NUMBLE DESCRIPTION IN TABLE 3	YE XIAOBING	x.x ±0.40	YE XIAOBING	2021/07/22	UNIT	mm	3601-PXXX-CXXMXXX01
AO	2020/12/05	NEW	Orwell	x.xx ±0.25	CHECK	DATE	SIZE	A4	TITLE:
				x.xxx ±0.15			SHEET	4/7	1.27mm BTB Male Header
				Angle ± 3°	APPROVE	DATE	PROJ.	Customer NO.	W=5.72, -SA STYLE, SMT
				DIM TOL					

WCON
Http: www.wcon.com

WCON-Dongguan Tel: +86 769 85358920 Fax: +86 769 85358915 E-mail: sales@wcon.com	WCON-Kunshan Tel: +86 512 57468408 Fax: +86 512 57468468 E-mail: salesks@wcon.com
---	--

HSF

Ordering Information

3601 - P XXX- C X X M XX X 01

No. Of Pins: _____
 04-100Pin
 (See Table 4)

Housing Locking: _____
 1=Without Locking+ Notch
 2=With Locking+Notch, Just For
 Housing Height 5.588mm
 3=With Locking+No Notch, Just
 For Housing Height 5.588mm
 (SEE TABLE 3)

Housing Height: _____
 1=5.588mm,
 2=7.366mm,
 3=9.144mm,
 4=11.049mm,
 (See Table 5)

Packaging : _____
 R=Tape & Reel+ Cap
 T=Tube
 P=Tube + Cap

Contact Plating: _____
 W2=5u" Gold/Matte Tin,
 W3=10u" Gold/Matte Tin,
 W4=15u" Gold/Matte Tin,
 W5=30u" Gold/Matte Tin,

TABLE 4:

PIN No.(HOUSING WITH LOCKING)	PIN No.(HOUSING WITHOUT LOCKING)	Part Number	DIM.A	DIM.B	DIM.C	DIM.N
NA	04	3601-P004-CXXMXXX01	5.72[.225]	1.27[.050]	3.18[.125]	4.45[.175]
NA	06	3601-P006-CXXMXXX01	6.99[.275]	2.54[.100]	4.45[.175]	5.72[.225]
NA	08	3601-P008-CXXMXXX01	8.26[.325]	3.81[.150]	5.72[.225]	6.99[.275]
10	10	3601-P010-CXXMXXX01	9.53[.375]	5.08[.200]	6.99[.275]	8.26[.325]
NA	12	3601-P012-CXXMXXX01	10.80[.425]	6.35[.250]	8.26[.325]	9.53[.375]
14	14	3601-P014-CXXMXXX01	12.07[.475]	7.62[.300]	9.53[.375]	10.80[.425]
16	16	3601-P016-CXXMXXX01	13.34[.525]	8.89[.350]	10.80[.425]	12.07[.475]
20	20	3601-P020-CXXMXXX01	15.88[.625]	11.43[.450]	13.34[.525]	14.61[.575]
30	30	3601-P030-CXXMXXX01	22.23[.875]	17.78[.700]	19.69[.775]	20.96[.825]
40	40	3601-P040-CXXMXXX01	28.58[1.125]	24.13[.950]	26.04[1.025]	27.31[1.075]
50	50	3601-P050-CXXMXXX01	34.93[1.375]	30.48[1.200]	32.39[1.275]	33.66[1.325]
60	60	3601-P060-CXXMXXX01	41.28[1.625]	36.83[1.450]	38.74[1.525]	40.01[1.575]
70	70	3601-P070-CXXMXXX01	47.63[1.875]	43.18[1.700]	45.09[1.775]	46.36[1.825]
80	80	3601-P080-CXXMXXX01	53.98[2.125]	49.53[1.950]	51.44[2.025]	52.71[2.075]
90	90	3601-P090-CXXMXXX01	60.33[2.375]	55.88[2.200]	57.79[2.275]	59.06[2.325]
100	100	3601-P100-CXXMXXX01	66.68[2.625]	62.23[2.450]	64.14[2.525]	65.41[2.575]

TABLE 5:

LEAD STYLE	Part Number	DIM.F	DIM.D	DIM.E	DIM.G	Overall Length For Pin(Short)
-02	3601-PXXX-CX1MXXX01	5.588[.2200]	3.59[.142]	NA	5.74[.226]	7.12[.280]
-12	3601-PXXX-CX2MXXX01	7.366[.2900]	3.59[.142]	NA	7.52[.296]	8.90[.350]
-22	3601-PXXX-CX3MXXX01	9.144[.3600]	3.59[.142]	NA	9.30[.366]	10.68[.420]
-32	3601-PXXX-CX4MXXX01	11.049[.4350]	3.59[.142]	NA	11.20[.441]	12.58[.495]

REV	DATE	MODIFICATION DESCRIPTION	CHANGE	OPERATION		DRAW YE XIAOBING	DATE 2021/07/22	SCALE	FIT	PART NO. 3601-PXXX-CXXMXXX01	TITLE: 1.27mm BTB Male Header W=5.72, -SA STYLE, SMT	Customer NO.	WCON	
				x.x	±0.40								Http: www.wcon.com	
A1	2021/07/22	ADD THE PIN NUMBLE DESCRIPTION IN TABLE 3	YE XIAOBING	x.xx	±0.25	CHECK	DATE	UNIT	mm inch				WCON-Dongguan	WCON-Kunshan
AO	2020/12/05	NEW	Orwell	x.xxx	±0.15			SIZE	A4				Tel: +86 769 85358920	Tel: +86 512 57468408
				Angle	± 3'	APPROVE	DATE	SHEET	5/7				Fax: +86 769 85358915	Fax: +86 512 57468468
				DIM	TOL			PROJ.					E-mail: sales@wcon.com	E-mail: salesks@wcon.com

HSF

TABLE 6:

	ASS'Y HIGH(H)		MALE	FEMALE	WIPE		
	3601-SS LEAD STYLE		H1	H2	FULLY MATED	MIN @ H MAX	
	-01, -03						
	FULLY MATED	MAX					
3601-PM LEAD STYLE	-02	6.17[.243]	6.63[.261]	5.74[.226]	4.57[.180]	0.84[.033]	0.38[.015]
	-12	7.95[.313]	8.41[.331]	7.52[.296]	4.57[.180]	0.84[.033]	0.38[.015]
	-22	9.73[.383]	10.19[.401]	9.30[.366]	4.57[.180]	0.84[.033]	0.38[.015]
	-32	11.63[.458]	12.09[.476]	11.20[.444]	4.57[.180]	0.84[.033]	0.38[.015]

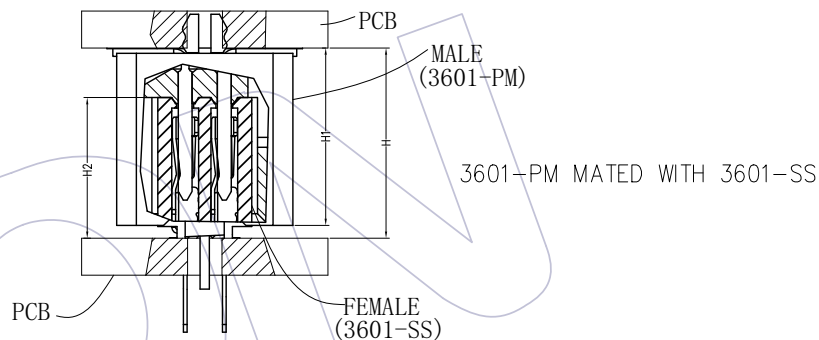
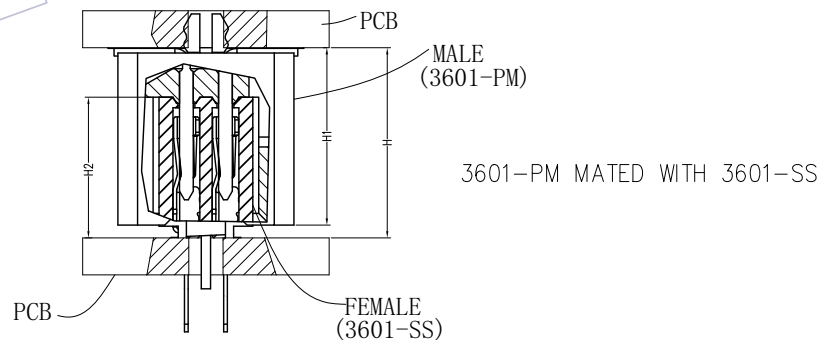

TABLE 7:

	ASS'Y HIGH(H)		MALE	FEMALE	WIPE		
	3601-SM LEAD STYLE		H1	H2	FULLY MATED	MIN @ H MAX	
	-02						
	FULLY MATED	MAX					
3601-PM LEAD STYLE	-02	6.30[.248]	6.76[.266]	5.74[.226]	4.83[.190]	0.84[.033]	0.38[.015]
	-12	8.08[.318]	8.54[.336]	7.52[.296]	4.83[.190]	0.84[.033]	0.38[.015]
	-22	9.86[.388]	10.32[.406]	9.30[.366]	4.83[.190]	0.84[.033]	0.38[.015]
	-32	11.76[.463]	12.22[.481]	11.20[.444]	4.83[.190]	0.84[.033]	0.38[.015]



REV	DATE	MODIFICATION DESCRIPTION	CHANGE	OPERATION		DRAW YE XIAOBING	DATE 2021/07/22	SCALE	FIT	PART NO. 3601-PXXX-CXXMXX01	TITLE: 1.27mm BTB Male Header W=5.72, -SA STYLE, SMT	WCON	
				x.x	±0.40							Http: www.wcon.com	
A1	2021/07/22	ADD THE PIN NUMBLE DESCRIPTION IN TABLE 3	YE XIAOBING	x.xx	±0.25	CHECK	DATE	UNIT	mm inch	Customer NO.	WCON-Dongguan Tel: +86 769 85358920 Fax: +86 769 85358915 E-mail: sales@wcon.com		
AO	2020/12/05	NEW	Orwell	x.xxx	±0.15	APPROVE	DATE	SIZE	A4		WCON-Kunshan Tel: +86 512 57468408 Fax: +86 512 57468468 E-mail: salesks@wcon.com		
				Angle	± 3'			PROJ.	6/7				

3601-PM MATED WITH 3601-SS

MATING DIRECTION

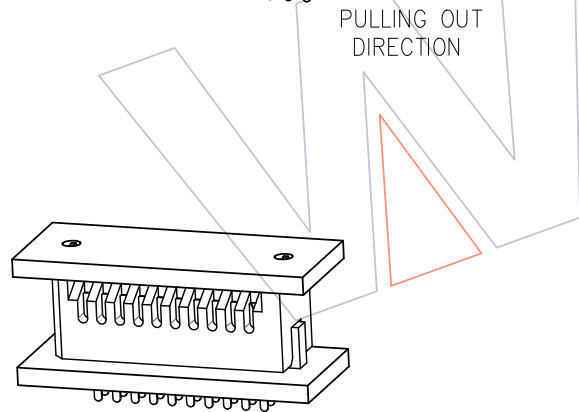
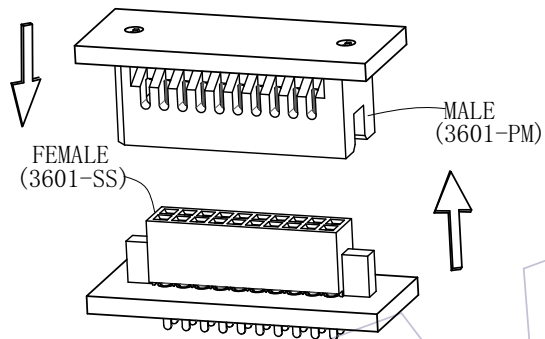

ASSEMBLY COMPLETION STATUS

3601-PM MATED WITH 3601-SM

MATING DIRECTION

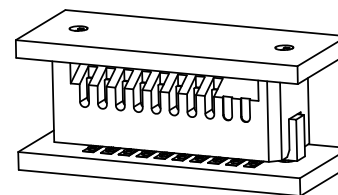
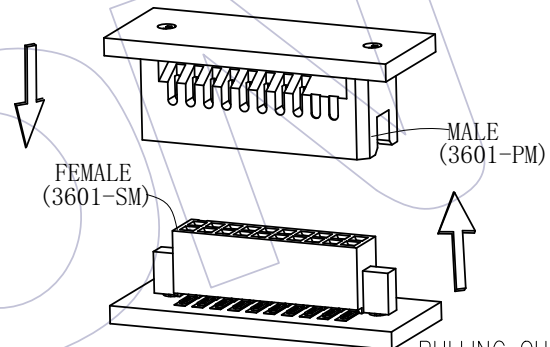

ASSEMBLY COMPLETION STATUS

				OPERATION	DRAW	DATE	SCALE	FIT	PART NO.	 Http: www.wcon.com
				X.X	YE XIAOBING	2021/07/22	UNIT	mm inch	3601-PXXX-CXXMXX01	
A1	2021/07/22	ADD THE PIN NUMBLE DESCRIPTION IN TABLE 3	YE XIAOBING	X.XX	CHECK	DATE	SIZE	A4	TITLE:	
AO	2020/12/05	NEW	Orwell	X.XXX	APPROVE	DATE	SHEET	7/7	1.27mm BTB Male Header W=5.72, -SA STYLE, SMT	
REV	DATE	MODIFICATION DESCRIPTION	CHANGE	Angle DIM	± 3' TOL		PROJ.	⊕	Customer NO.	WCON-Dongguan Tel: +86 769 85358920 Fax: +86 769 85358915 E-mail: sales@wcon.com
										WCON-Kunshan Tel: +86 512 57468408 Fax: +86 512 57468468 E-mail: salesks@wcon.com