

# HSF

**NOTES:**

Rated Current: 3.0AMP.(20°C,2\*2P-2\*15P)  
 2.0AMP.(20°C,2\*16P-2\*40P)  $\triangle A4$   
 Contact Resistance: 20m $\Omega$  Max.  
 Withstand Voltage: 500V AC/DC  
 Insulation Resistance: 1000M $\Omega$  Min.  
 Operation Temperature: -40°C to +125°C(Gold Plating)  
 -40°C to +105°C(Tin Plating)  $\triangle A2$   $\triangle A4$   
 Contact Material: Copper Alloy  
 Contact Plating: Au or Sn Over 30u" Min Ni  $\triangle A4$   
 Insulator Material: PA9T+G.F UL94V-0 BK

## Ordering Information

1215- 2 2 XX XX M XXX C R XX  $\triangle A1$

Plastic Layer  
 Plastic Row  
 No. of Pins  
 Per Row: 02-40  
 Contact Plating  
 G0=Gold Flash  
 G3=10u"Au, BG3=8u"PdNi+2u"Au  
 G4=15u"Au, BG4=13u"PdNi+2u"Au  
 G5=30u"Au, BG5=28u"PdNi+2u"Au  
 S0=Gold Flash/Tin  
 S3=10u"Au/Sn, P3=8u"PdNi+2u"Au/Sn  
 S4=15u"Au/Sn, P4=13u"PdNi+2u"Au/Sn  
 S5=30u"Au/Sn, P5=28u"PdNi+2u"Au/Sn  $\triangle A4$   
 SN=Bright Tin  
 SM=Matte Tin  
 Series No.  
 01-99  
 Packing  
 T=Tube  
 P=Tube+CAP  
 R=Tape&Reel+CAP  
 Insulator Material  
 C=PA9T  
 Pin Length  
 L(See Table)  
 Type:  
 M:SMT

PIN	2-15P	16-25P	26-40P	$\triangle A2$
M	0.10	0.15	0.20	

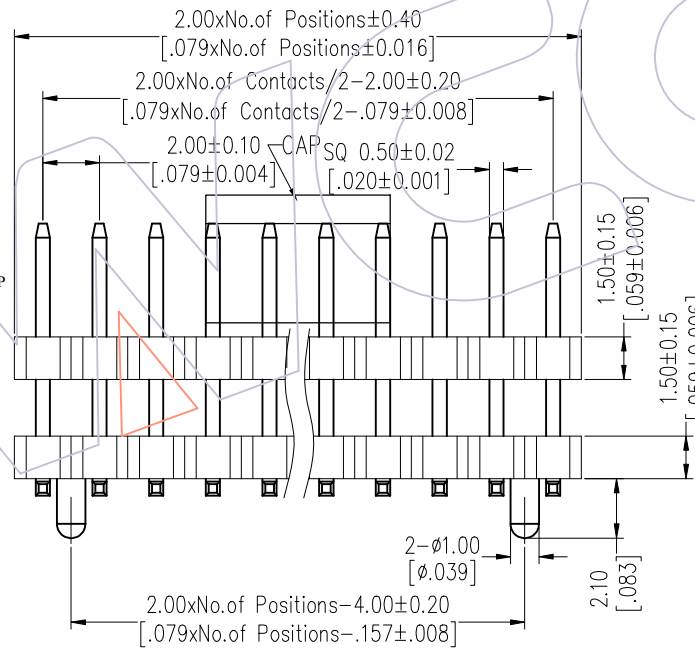
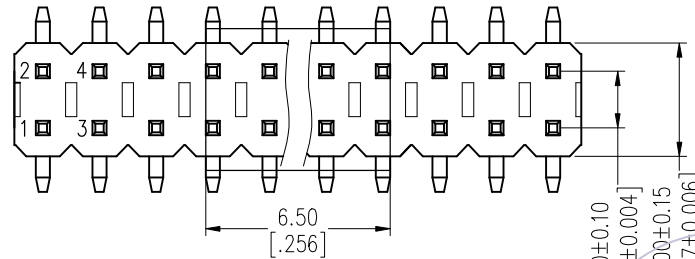

Recommended P.C.B Layout (Top Side)  
 (PCB BOARD TOLERANCE±0.05)  
 (PCB Thickness:T=1.60m)

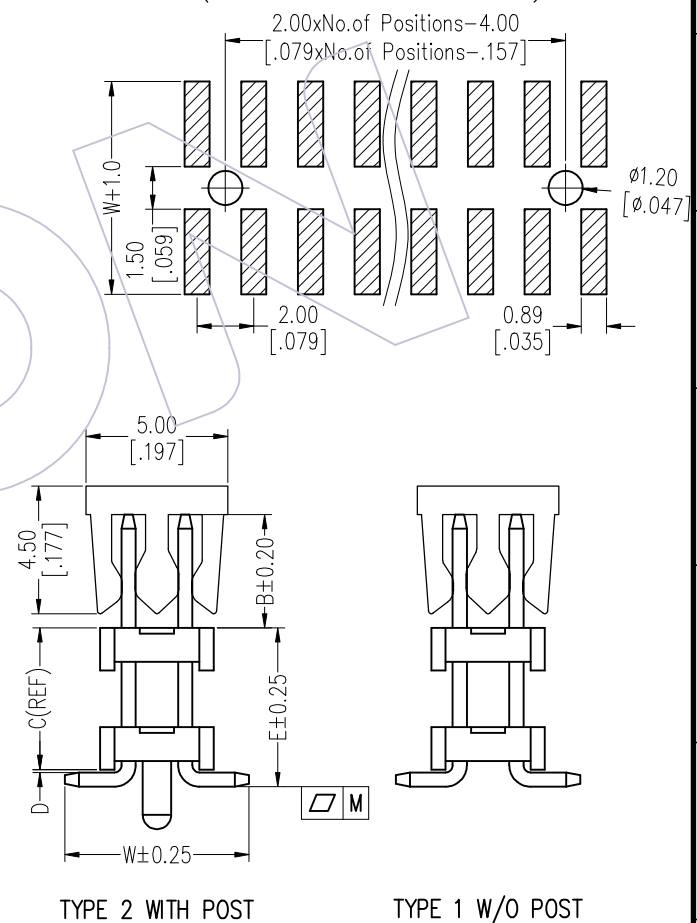

A4	2025/08/01	Standardization Drawing	CP	OPERATION	DRAW	DATE	SCALE	Fit	PART NO.
A3	2023/09/21	Modify Plastic Appearance	DuYing	x.X ±0.40	CP	2025/08/01	UNIT	mm	1215-22XXXXMXXCRXX $\triangle A1$
A2	2018/09/07	Modify	Ding	x.XX ±0.25	CHECK	DATE	SIZE	A4	TITLE:
A0	2012/04/18	NEW	William Chen	x.XXX ±0.15	TANG	2025/08/01	SHEET	1/5	PH2.00 DUAL ROW DOUBLE PLASTIC SMT H=1.5
REV	DATE	MODIFICATION DESCRIPTION	CHANGE	Angle ± 3°	APPROVE	DATE	PROJ.		Customer NO.
				DIM TOL	Steven Zhao	2025/08/01			

**WCON**  
 Http: www.wcon.com  
 WCON-Dongguan Tel: +86 769 85358920 Fax: +86 769 85358915 E-mail: sales@wcon.com  
 WCON-Kunshan Tel: +86 512 57468408 Fax: +86 512 57468468 E-mail: salesks@wcon.com

# HSF

## Packing:

Tube:

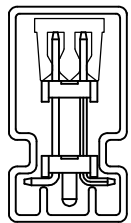

W/T Post

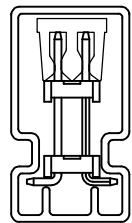

W/O Post

Tube

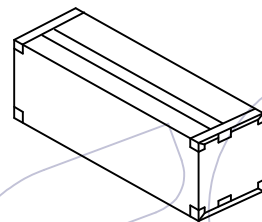
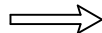

Inner Box

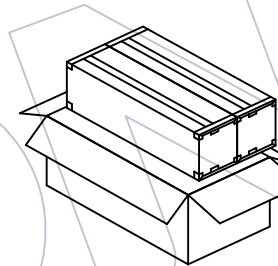

Box

Reel:

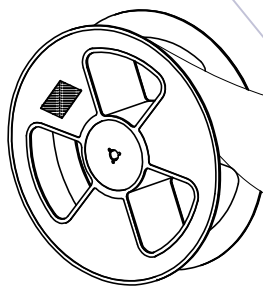

客户安装时拉出方向  
Customer pull out direction



Round

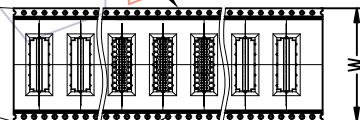

Ellipse

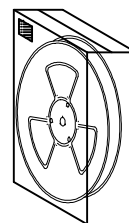
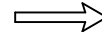

Inner Box

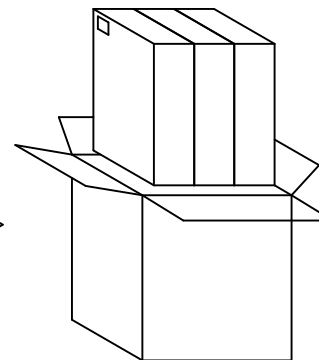
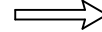

Box (Put in 3 Inner Box)

A4	2025/08/01	Standardization Drawing	CP	OPERATION	DRAW	DATE	SCALE	Fit	PART NO.
A3	2023/09/21	Modify Plastic Appearance	DuYing	x.X ±0.40	CP	2025/08/01	UNIT	mm	1215-22XXXXMXXCRXX $\Delta$
A2	2018/09/07	Modify	Ding	x.XX ±0.25	CHECK	DATE	SIZE	A4	TITLE:
A0	2012/04/18	NEW	William Chen	x.XXX ±0.15	TANG	2025/08/01	SHEET	2/5	PH2.00 DUAL ROW DOUBLE PLASTIC SMT H=1.5
REV	DATE	MODIFICATION DESCRIPTION	CHANGE	Angle ± 3°	APPROVE	DATE	PROJ.		Customer NO.
				DIM TOL	Steven Zhao	2025/08/01			

# WCON

Http: [www.wcon.com](http://www.wcon.com)

WCON-Dongguan  
Tel: +86 769 85358920  
Fax: +86 769 85358915  
E-mail: [sales@wcon.com](mailto:sales@wcon.com)

WCON-Kunshan  
Tel: +86 512 57468408  
Fax: +86 512 57468468  
E-mail: [salesks@wcon.com](mailto:salesks@wcon.com)

# HSF

## Packaging Quantity Refers To The Following Table

E=4.3//E=5.4,B=2.52/3.0/3.5

E=4.3//E=5.4,B=2.52/3.0/3.5

Item	L	E	C	D	W	B	Mating
Standard	8.5	4.3	3.0	0.8	4.5	2.5	2220T/2221/2228
	9.0					3.0	2227T/2228T/2245
	9.5					3.5	2235/2240N/2243C
	10.0					4.0	2240/2243/2245T/2263/2272
	9.5	5.4	4.8	0.1		2.5	2220T/2221/2228
	10.0					3.0	2227T/2228T/2245
	10.5					3.5	2235/2240N/2243C
	11.0					4.0	2240/2243/2245T/2263/2272
	11.8	7.5	6.9	0.1		2.5	2220T/2221/2228
	12.3					3.0	2227T/2228T/2245
	12.8					3.5	2235/2240N/2243C
	13.3					4.0	2240/2243/2245T/2263/2272
	12.8	8.5	7.9	0.1		2.5	2220T/2221/2228
	13.3					3.0	2227T/2228T/2245
	13.8					3.5	2235/2240N/2243C
	14.2					4.0	2240/2243/2245T/2263/2272
	13.8	9.5	8.8	0.2		2.5	2220T/2221/2228
	14.2					3.0	2227T/2228T/2245
	14.8					3.5	2235/2240N/2243C
	15.3					4.0	2240/2243/2245T/2263/2272
16.3	12.0	11.4	0.1	2.5	2220T/2221/2228		
16.8				3.0	2227T/2228T/2245		
17.3				3.5	2235/2240N/2243C		
17.8				4.0	2240/2243/2245T/2263/2272		
Alternate							

PINS /Row	Q'ty/Tube	Q'ty/Inner Box	Q'ty/Box
4	72	4,320	8,640
5	58	3,480	6,960
6	48	2,880	5,760
7	41	2,460	4,920
8	36	2,160	4,320
9	31	1,860	3,720
10	29	1,740	3,480
11	25	1,500	3,000
12	23	1,380	2,760
13	21	1,260	2,520
14	20	1,200	2,400
15	19	1,140	2,280
16	17	1,020	2,040
17	16	960	1,920
18	15	900	1,800
19	15	900	1,800
20	14	840	1,680
21	13	780	1,560
22	13	780	1,560

PINS /Row	Q'ty/Tube	Q'ty/Inner Box	Q'ty/Box
23	12	720	1,440
24	11	660	1,320
25	11	660	1,320
26	11	660	1,320
27	10	600	1,200
28	10	600	1,200
29	9	540	1,080
30	9	540	1,080
31	9	540	1,080
32	9	540	1,080
33	8	480	960
34	8	480	960
35	8	480	960
36	8	480	960
37	7	420	840
38	7	420	840
39	7	420	840
40	7	420	840

A4	2025/08/01	Standardization Drawing	CP	OPERATION	DRAW	DATE	SCALE	Fit	PART NO.
A3	2023/09/21	Modify Plastic Appearance	DuYing	x.X ±0.40	CP	2025/08/01	UNIT	mm	1215-22XXXXMXXCRXX ▲
A2	2018/09/07	Modify	Ding	x.XX ±0.25	CHECK	DATE	SIZE	A4	TITLE:
A0	2012/04/18	NEW	William Chen	x.XXX ±0.15	TANG	2025/08/01	SHEET	3/5	PH2.00 DUAL ROW DOUBLE PLASTIC SMT H=1.5
REV	DATE	MODIFICATION DESCRIPTION	CHANGE	Angle ± 3°	APPROVE	DATE	PROJ.	Customer NO.	
				DIM TOL	Steven Zhao	2025/08/01			



Http: www.wcon.com

WCON-Dongguan Tel: +86 769 85358920 Fax: +86 769 85358915 E-mail: sales@wcon.com

WCON-Kunshan Tel: +86 512 57468408 Fax: +86 512 57468468 E-mail: salesks@wcon.com

# HSF

## Packaging Quantity Refers To The Following Table

E=5.4,B=4.0//E=7.5/8.5/9.5/12.0

PINS /Row	Q'ty/Tube	Q'ty/Inner Box	Q'ty/Box
4	72	8,640	17,280
5	58	6,960	13,920
6	48	5,760	11,520
7	41	4,920	9,840
8	36	4,320	8,640
9	31	3,720	7,440
10	29	3,480	6,960
11	25	3,000	6,000
12	23	2,760	5,520
13	21	2,520	5,040
14	20	2,400	4,800
15	19	2,280	4,560
16	17	2,040	4,080
17	16	1,920	3,840
18	15	1,800	3,600
19	15	1,800	3,600
20	14	1,680	3,360
21	13	1,560	3,120
22	13	1,560	3,120

E=5.4,B=4.0//E=7.5/8.5/9.5/12.0

PINS /Row	Q'ty/Tube	Q'ty/Inner Box	Q'ty/Box
23	12	1,440	2,880
24	11	1,320	2,640
25	11	1,320	2,640
26	11	1,320	2,640
27	10	1,200	2,400
28	10	1,200	2,400
29	9	1,080	2,160
30	9	1,080	2,160
31	9	1,080	2,160
32	9	1,080	2,160
33	8	960	1,920
34	8	960	1,920
35	8	960	1,920
36	8	960	1,920
37	7	840	1,680
38	7	840	1,680
39	7	840	1,680
40	7	840	1,680

E=4.3

PINS /Row	W	Q'ty/Reel	Q'ty/Inner Box	Q'ty/Box
2	24	370	1,110	3,330
3	24	370	1,110	3,330
4	24	370	1,110	3,330
5	24	370	1,110	3,330
6	32	370	740	2,220
7	32	370	740	2,220
8	44	370	740	2,220
9	44	370	740	2,220
10	44	370	740	2,220
11	44	370	740	2,220
12	44	370	740	2,220
13	44	370	740	2,220
14	56	370	370	1,110
15	56	370	370	1,110
16	56	370	370	1,110
17	56	370	370	1,110
18	56	370	370	1,110
19	56	370	370	1,110
20	72	370	370	1,110
21	72	370	370	1,110
22	72	370	370	1,110
23	72	370	370	1,110
24	72	370	370	1,110
25	72	370	370	1,110
26	72	370	370	1,110
27	72	370	370	1,110
28	88	370	370	1,110
29	88	370	370	1,110
30	88	370	370	1,110

E=5.4

PINS /Row	W	Q'ty/Reel	Q'ty/Inner Box	Q'ty/Box
2	24	290	870	2,610
3	24	290	870	2,610
4	24	290	870	2,610
5	24	290	870	2,610
6	32	290	580	1,740
7	44	290	580	1,740
8	44	290	580	1,740
9	44	290	580	1,740
10	44	290	580	1,740
11	44	290	580	1,740
12	44	290	580	1,740
13	56	290	290	870
14	56	290	290	870
15	56	290	290	870
16	56	290	290	870
17	56	290	290	870
18	56	290	290	870
19	72	290	290	870
20	72	290	290	870
21	72	290	290	870
22	72	290	290	870
23	72	290	290	870
24	72	290	290	870
25	72	290	290	870
26	72	290	290	870
27	88	290	290	870
28	88	290	290	870
29	88	290	290	870
30	88	290	290	870

A4	2025/08/01	Standardization Drawing	CP	OPERATION	DRAW	DATE	SCALE	Fit	PART NO. 1215-22XXXXMXXCRXX $\Delta$
A3	2023/09/21	Modify Plastic Appearance	DuYing	x.X ±0.40	CP	2025/08/01	UNIT	mm	
A2	2018/09/07	Modify	Ding	x.XX ±0.25	CHECK	DATE	SIZE	A4	TITLE: PH2.00 DUAL ROW DOUBLE PLASTIC SMT H=1.5
A0	2012/04/18	NEW	William Chen	x.XXX ±0.15	TANG	2025/08/01	SHEET	4/5	
REV	DATE	MODIFICATION DESCRIPTION	CHANGE	Angle ± 3°	APPROVE	DATE	PROJ.	Customer NO.	
				DIM TOL	Steven Zhao	2025/08/01			



WCON-Dongguan Tel: +86 769 85358920 Fax: +86 769 85358915 E-mail: sales@wcon.com	WCON-Kunshan Tel: +86 512 57468408 Fax: +86 512 57468468 E-mail: salesks@wcon.com
---	--



Packaging Quantity Refers To The Following Table

E=7.5//E=8.5,B=2.5/3.0/3.5

PINS /Row	W	Q'ty/Reel	Q'ty/Inner Box	Q'ty/Box
2	24	250	750	2,250
3	24	250	750	2,250
4	24	250	750	2,250
5	32	250	500	1,500
6	32	250	500	1,500
7	44	250	500	1,500
8	44	250	500	1,500
9	44	250	500	1,500
10	44	250	500	1,500
11	44	250	500	1,500
12	44	250	500	1,500
13	56	250	250	750
14	56	250	250	750
15	56	250	250	750
16	56	250	250	750
17	56	250	250	750
18	56	250	250	750
19	72	250	250	750
20	72	250	250	750
21	72	250	250	750
22	72	250	250	750
23	72	250	250	750
24	72	250	250	750
25	72	250	250	750
26	72	250	250	750
27	88	250	250	750
28	88	250	250	750
29	88	250	250	750
30	88	250	250	750

E=8.5,B=4.0//E=9.5

PINS /Row	W	Q'ty/Reel	Q'ty/Inner Box	Q'ty/Box
2	24	170	510	1,530
3	24	170	510	1,530
4	24	170	510	1,530
5	32	170	340	1,020
6	32	170	340	1,020
7	44	170	340	1,020
8	44	170	340	1,020
9	44	170	340	1,020
10	44	170	340	1,020
11	44	170	340	1,020
12	56	170	170	510
13	56	170	170	510
14	56	170	170	510
15	56	170	170	510
16	56	170	170	510
17	56	170	170	510
18	72	170	170	510
19	72	170	170	510
20	72	170	170	510
21	72	170	170	510
22	72	170	170	510
23	72	170	170	510
24	72	170	170	510
25	72	170	170	510
26	88	170	170	510
27	88	170	170	510
28	88	170	170	510
29	88	170	170	510
30	88	170	170	510

E=12.0

PINS /Row	W	Q'ty/Reel	Q'ty/Inner Box	Q'ty/Box
2	24	130	390	1,170
3	24	130	390	1,170
4	32	130	260	780
5	32	130	260	780
6	44	130	260	780
7	44	130	260	780
8	44	130	260	780
9	44	130	260	780
10	44	130	260	780
11	56	130	130	130
12	56	130	130	130
13	56	130	130	130
14	56	130	130	130
15	56	130	130	130
16	56	130	130	130
17	72	130	130	130
18	72	130	130	130
19	72	130	130	130
20	72	130	130	130
21	72	130	130	130
22	72	130	130	130
23	72	130	130	130
24	72	130	130	130
25	88	130	130	130
26	88	130	130	130
27	88	130	130	130
28	88	130	130	130
29	88	130	130	130
30	88	130	130	130

A4	2025/08/01	Standardization Drawing	CP	OPERATION	DRAW	DATE	SCALE	Fit	PART NO.
A3	2023/09/21	Modify Plastic Appearance	DuYing	x.X ±0.40	CP	2025/08/01	UNIT	mm	1215-22XXXXMXXCRXX $\Delta$
A2	2018/09/07	Modify	Ding	x.XX ±0.25	CHECK	DATE	SIZE	A4	TITLE:
A0	2012/04/18	NEW	William Chen	x.XXX ±0.15	TANG	2025/08/01	SHEET	5/5	PH2.00 DUAL ROW DOUBLE PLASTIC SMT H=1.5
REV	DATE	MODIFICATION DESCRIPTION	CHANGE	Angle ± 3°	APPROVE	DATE	PROJ.		Customer NO.
				DIM TOL	Steven Zhao	2025/08/01			



Http: www.wcon.com  
 WCON-Dongguan Tel: +86 769 85358920  
 WCON-Kunshan Tel: +86 512 57468408  
 Fax: +86 769 85358915 Fax: +86 512 57468468  
 E-mail: sales@wcon.com E-mail: salesks@wcon.com