

# HSF

NOTES:  $\triangle A4$

Rated Current: 1.5AMP.(20°C, 1\*2P-1\*15P)  
 1.0AMP.(20°C, 1\*16P-1\*50P)  
 Contact Resistance: 20mΩ Max.  
 Withstand Voltage: 500V AC/DC  
 Insulation Resistance: 1000MΩ Min.  
 Operation Temperature: -40°C to +125°C(Gold Plating)

Contact Material: Copper Alloy  
 Contact Plating: Au Over 30u" Min Ni  
 Insulator Material: PA9T+G.F UL94V-0 BK

## Ordering Information $\triangle A4$

**2334- 1 XX M XX C U N X X**

Plastic Row  
 No. of Pins  
 Per Row: 02-50  
 Welding Type  
 M=SMT

Series No.  
 1=Type 1  
 2=Type 2

Packing:  
 T=Tube  
 P=Tube+CAP  
 R=Tape&Reel+CAP

Contact Plating  
 G0=Gold Flash  
 G3=10u"Au, BG3=8u"PdNi+2u"Au  
 G4=15u"Au, BG4=13u"PdNi+2u"Au  
 G5=30u"Au, BG5=28u"PdNi+2u"Au

Logo  
 N=W/O Logo

Contact Type  
 U=U Type

Insulator Material  
 C=PA9T

Recommended P.C.B Layout(Top Side)  
 (PCB BOARD TOLERANCE  $\pm 0.05$ )  
 (PCB Thickness: T=1.60mm)

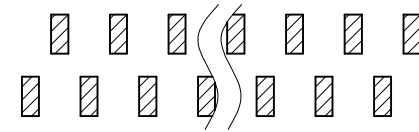
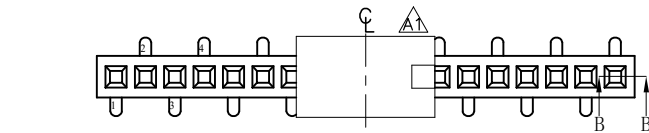

Type 1

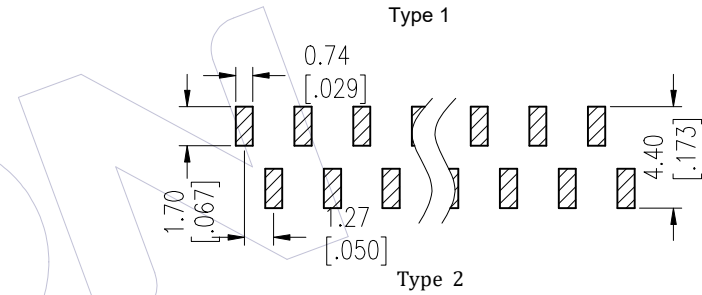

Type 2

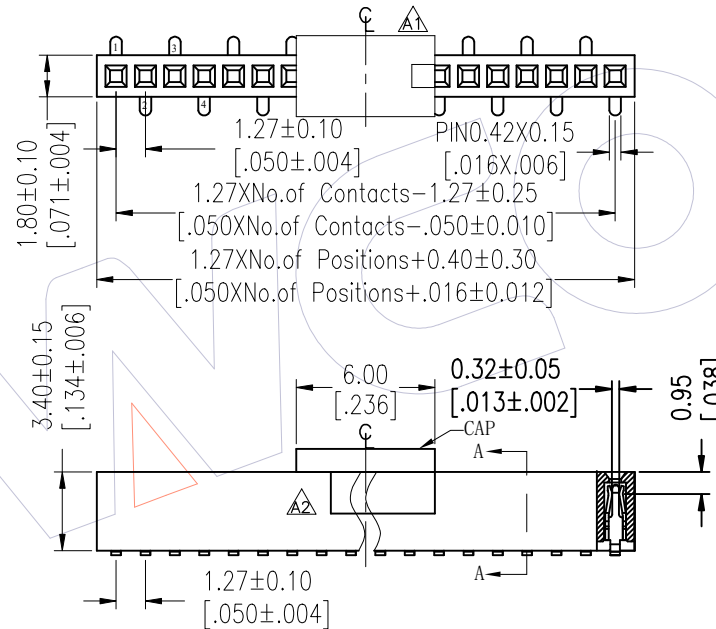

SECTION B-B

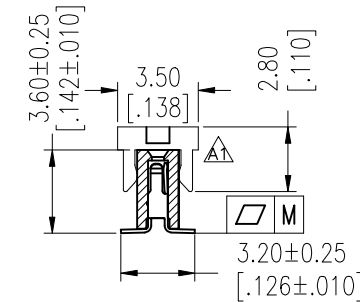

SECTION A-A

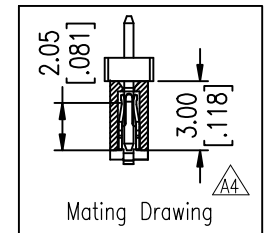

Mating Drawing

Item	Pitch	Mating	DIM.B
Standard	1.27	1310/1315/1320	3.00
Alternate			

$\triangle A3$	Pin(Per Row)	2-15P	16-30P	31-50P
	M	0.10	0.15	0.18

TITLE	PART NO.
TYPE 1	2334-1XXMXXCUNX1
TYPE 2	2334-1XXMXXCUNX2

REV	DATE	MODIFICATION DESCRIPTION	CHANGE	DIM	TOL	APPROVE	DATE	SCALE	FIT	PART NO.
A4	2025/12/17	Standardization Drawing	BAO			OPERATION	DATE	SCALE	FIT	PART NO.
A3	2023/02/03	ADD Flatness	XSR	x.x	$\pm 0.40$	DRAW	2025/12/17	UNIT	mm	SEE TABLE
A2	2017/04/14	MODIFY CAP	-----	x.xx	$\pm 0.25$	CHECK	DATE	SIZE	A4	TITLE:
A0	2012/07/06	NEW	-----	x.xxx	$\pm 0.15$	TANG	2025/12/17	SHEET	1/4	1.27mm Female Header SINGLE ROW
				Angle	$\pm 3'$	APPROVE	DATE	PROJ.	$\phi$	180'SMT H=3.40
						Steven Zhao	2025/12/17			Customer NO.

**WCON**  
 Http: www.wcon.com

WCON-Dongguan  
 Tel: +86 769 85358920  
 Fax: +86 769 85358915  
 E-mail: sales@wcon.com

WCON-Kunshan  
 Tel: +86 512 57468408  
 Fax: +86 512 57468468  
 E-mail: salesks@wcon.com

**HSF**

**Packing:**



**Tube:**

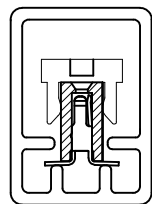

W/T CAP

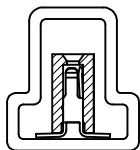

W/O CAP

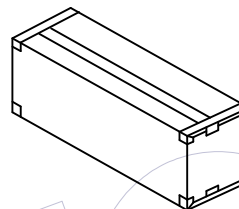

Inner Box

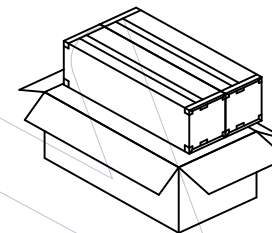

Box

**Reel:**

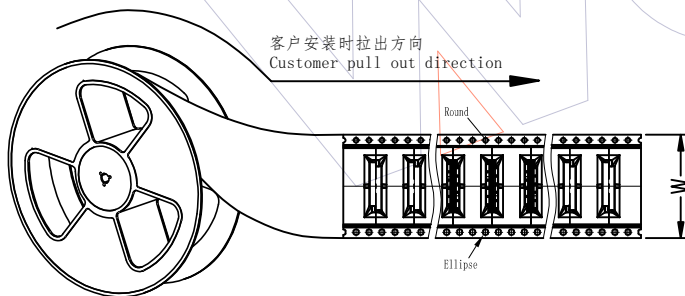

客户安装时拉出方向  
Customer pull out direction

Round

Ellipse

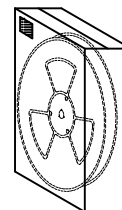

Inner Box

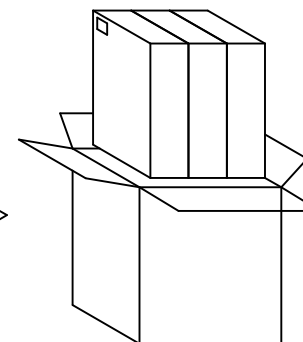

Box (Put in 3 Inner Box)

A4	2025/12/17	Standardization Drawing	BAO	OPERATION	DRAW BAO	DATE	SCALE	FIT	PART NO.
A3	2023/02/03	ADD Flatness	XSR	x.X ±0.40	CHECK TANG	2025/12/17	UNIT	mm	SEE TABLE
A2	2017/04/14	MODIFY CAP	-----	x.XX ±0.25		DATE	SIZE	A4	TITLE:
A0	2012/07/06	NEW	-----	x.XXX ±0.15	APPROVE Steven Zhao	2025/12/17	SHEET	2/4	1.27mm Female Header SINGLE ROW
REV	DATE	MODIFICATION DESCRIPTION	CHANGE	Angle ± 3'		DATE	PROJ.	Customer NO.	
				DIM TOL		2025/12/17			

**WCON**

Http: www.wcon.com

WCON-Dongguan  
Tel: +86 769 85358920  
Fax: +86 769 85358915  
E-mail: sales@wcon.com

WCON-Kunshan  
Tel: +86 512 57468408  
Fax: +86 512 57468468  
E-mail: salesks@wcon.com



## Packaging Quantity Refers To The Following Table

W/T CAP

W/T CAP

W/O CAP

W/O CAP

PINS	Q' ty/Tube	Q' ty/Inner Box	Q' ty/Box
2	/	/	/
3	96	28,800	57,600
4	96	28,800	57,600
5	85	25,500	57,600
6	72	21,600	57,600
7	62	18,600	57,600
8	55	16,500	57,600
9	49	14,700	57,600
10	44	13,200	57,600
11	40	12,000	57,600
12	36	10,800	57,600
13	34	10,200	57,600
14	31	9,300	57,600
15	29	8,700	57,600
16	28	8,400	57,600
17	26	7,800	57,600
18	25	7,500	57,600
19	23	6,900	57,600
20	22	6,600	57,600
21	21	6,300	57,600
22	20	6,000	57,600
23	19	5,700	57,600
24	18	5,400	57,600
25	18	5,400	57,600
26	17	5,100	57,600

PINS	Q' ty/Tube	Q' ty/Inner Box	Q' ty/Box
27	16	4,800	57,600
28	16	4,800	57,600
29	15	4,500	57,600
30	15	4,500	57,600
31	14	4,200	57,600
32	14	4,200	57,600
33	13	3,900	57,600
34	13	3,900	57,600
35	12	3,600	57,600
36	12	3,600	57,600
37	12	3,600	57,600
38	11	3,300	57,600
39	11	3,300	57,600
40	11	3,300	57,600
41	10	3,000	57,600
42	10	3,000	57,600
43	10	3,000	57,600
44	10	3,000	57,600
45	10	3,000	57,600
46	9	2,700	57,600
47	9	2,700	57,600
48	9	2,700	57,600
49	9	2,700	57,600
50	9	2,700	57,600

PINS	Q' ty/Tube	Q' ty/Inner Box	Q' ty/Box
2	1,500/Tray	/	72,000
3	137	68,500	137,000
4	104	52,000	104,000
5	85	42,500	85,000
6	72	36,000	72,000
7	62	31,000	62,000
8	55	27,500	55,000
9	49	24,500	49,000
10	44	22,000	44,000
11	40	20,000	40,000
12	36	18,000	36,000
13	34	17,000	34,000
14	31	15,500	31,000
15	29	14,500	29,000
16	28	14,000	28,000
17	26	13,000	26,000
18	25	12,500	25,000
19	23	11,500	23,000
20	22	11,000	22,000
21	21	10,500	21,000
22	20	10,000	20,000
23	19	9,500	19,000
24	18	9,000	18,000
25	18	9,000	18,000
26	17	8,500	17,000

PINS	Q' ty/Tube	Q' ty/Inner Box	Q' ty/Box
27	16	8,000	16,000
28	16	8,000	16,000
29	15	7,500	15,000
30	15	7,500	15,000
31	14	7,000	14,000
32	14	7,000	14,000
33	13	6,500	13,000
34	13	6,500	13,000
35	12	6,000	12,000
36	12	6,000	12,000
37	12	6,000	12,000
38	11	5,500	11,000
39	11	5,500	11,000
40	11	5,500	11,000
41	10	5,000	10,000
42	10	5,000	10,000
43	10	5,000	10,000
44	10	5,000	10,000
45	10	5,000	10,000
46	9	4,500	9,000
47	9	4,500	9,000
48	9	4,500	9,000
49	9	4,500	9,000
50	9	4,500	9,000

A4	2025/12/17	Standardization Drawing	BAO	OPERATION	DRAW BAO	DATE	SCALE	FIT	PART NO.
A3	2023/02/03	ADD Flatness	XSR	x.X ±0.40	CHECK BAO	2025/12/17	UNIT	mm	SEE TABLE
A2	2017/04/14	MODIFY CAP	-----	x.XX ±0.25	CHECK TANG	DATE	SIZE	A4	TITLE:
A0	2012/07/06	NEW	-----	x.XXX ±0.15	APPROVE Steven Zhao	2025/12/17	SHEET	3/4	1.27mm Female Header SINGLE ROW 180'SMT H=3.40
REV	DATE	MODIFICATION DESCRIPTION	CHANGE	Angle ± 3' DIM TOL		DATE	PROJ.	Customer NO.	



Http: www.wcon.com

WCON-Dongguan Tel: +86 769 85358920 Fax: +86 769 85358915 E-mail: sales@wcon.com	WCON-Kunshan Tel: +86 512 57468408 Fax: +86 512 57468468 E-mail: salesks@wcon.com
---	--

HSF

Packaging Quantity Refers To The Following Table

PINS	W	Q' ty/Reel	Q' ty/Inner Box	Q' ty/Box
2	16	1,000	4,000	12,000
3	16	1,000	4,000	12,000
4	16	1,000	4,000	12,000
5	24	1,000	3,000	9,000
6	24	1,000	3,000	9,000
7	24	900	2,700	8,100
8	24	1,000	3,000	9,000
9	24	1,000	3,000	9,000
10	24	1,000	3,000	9,000
11	32	1,000	2,000	6,000
12	32	1,000	2,000	6,000
13	32	1,000	2,000	6,000
14	32	1,000	2,000	6,000
15	32	1,000	2,000	6,000
16	32	1,000	2,000	6,000
17	44	1,000	2,000	6,000
18	44	1,000	2,000	6,000
19	44	1,000	2,000	6,000
20	44	1,000	2,000	6,000
21	44	1,000	2,000	6,000
22	44	1,000	2,000	6,000
23	44	1,000	2,000	6,000
24	44	1,000	2,000	6,000
25	44	1,000	2,000	6,000
26	56	1,000	1,000	3,000

PINS	W	Q' ty/Reel	Q' ty/Inner Box	Q' ty/Box
27	56	1,000	1,000	3,000
28	56	1,000	1,000	3,000
29	56	1,000	1,000	3,000
30	56	1,000	1,000	3,000
31	56	1,000	1,000	3,000
32	56	1,000	1,000	3,000
33	56	1,000	1,000	3,000
34	56	1,000	1,000	3,000
35	56	1,000	1,000	3,000
36	72	1,000	1,000	3,000
37	72	1,000	1,000	3,000
38	72	1,000	1,000	3,000
39	72	1,000	1,000	3,000
40	72	1,000	1,000	3,000
41	72	1,000	1,000	3,000
42	72	1,000	1,000	3,000
43	72	1,000	1,000	3,000
44	72	1,000	1,000	3,000
45	72	1,000	1,000	3,000
46	72	1,000	1,000	3,000
47	72	1,000	1,000	3,000
48	88	1,000	1,000	3,000
49	88	1,000	1,000	3,000
50	88	1,000	1,000	3,000

REV	DATE	MODIFICATION DESCRIPTION	CHANGE	DIM	TOL	APPROVE	DATE	PROJ.	SHEET	FIT	PART NO.
A4	2025/12/17	Standardization Drawing	BAO			DRAW	2025/12/17				SEE TABLE
A3	2023/02/03	ADD Flatness	XSR	x.X	±0.40	BAO	2025/12/17				
A2	2017/04/14	MODIFY CAP	-----	x.xx	±0.25	CHECK	2025/12/17				
A0	2012/07/06	NEW	-----	x.xxx	±0.15	TANG	2025/12/17				
				Angle	± 3'	APPROVE	2025/12/17		4/4		
						Steven Zhao	2025/12/17				

**WCON**  
 Http: www.wcon.com  
 WCON-Dongguan Tel: +86 769 85358920  
 WCON-Kunshan Tel: +86 512 57468408  
 Fax: +86 769 85358915 Fax: +86 512 57468468  
 E-mail: sales@wcon.com E-mail: salesks@wcon.com